

Cast Steel Bolted Bonnet Gate Valves

Bolted Bonnet, Outside Screw & Yoke, Rising Stem, Non-rising Handwheel, Flexible Wedge.



Features

- Design and manufacture: API 600
- Face-to-Face dimension: 36"and smaller to ASME B16.10, 40"and larger to manufacturer's standard
- Flanged End: 24"and smaller to ASME B16.5 26"and larger to ASME B16.47 series A
- B.W. End: ASME B16.25
- Shell Wall Thickness: 24"and smaller to API 600 26"and larger to manufacturer's standard
- 8"and smaller valves have a one-piece bonnet and yoke design 10"and larger valves have a split bonnet and yoke design.

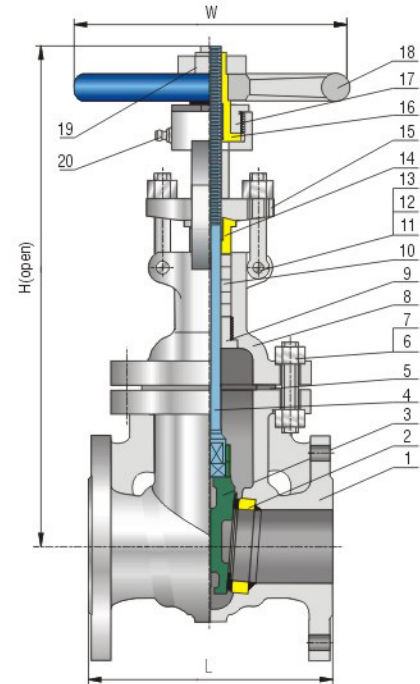

Parts List

No.	Parts	Material
1	Body	ASTM A216 Gr.WCB
2	Seat ring	ASTM A105+ 13Cr
3	Wedge	ASTM A216 WCB+ 13Cr
4	Stem	ASTM A182 F6a
5	Gasket	304S.S. Jacketed Graphite
6	Bonnet bolt	ASTM A193 Gr.B7
7	Bonnet nut	ASTM A194 Gr.2H
8	Bonnet	ASTM A216 Gr.WCB
9	Back seat	ASTM A276 410
10	Packing	Graphite
11	Pin	C.S.
12	Gland bolt	ASTM A193 Gr.B7
13	Gland nut	ASTM A194 Gr.2H
14	Gland	ASTM A276 410
15	Gland flange	ASTM A216 Gr.WCB
16	Stem nut	Aluminum Bronze
17	Retaining nut	C.S.
18	Handwheel	Malleable Iron
19	H.W. lock nut	C.S.
20	Lubricator	Assem.

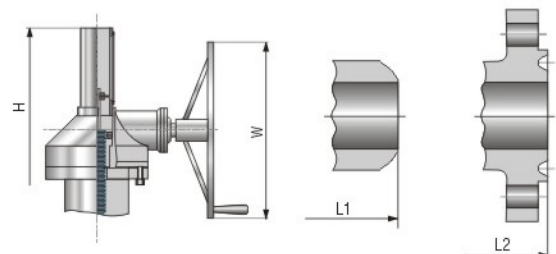

• Gear operation for 14" and larger BW End RTJ End

Dimensions & Weights

Valve Size	in. mm	1-1/2 40	2 50	2-1/2 65	3 80	4 100	5 125	6 150	8 200	10 250	12 300	14 350	16 400	18 450	20 500	24 600	28 700	30 750	32 800	36 900	40 1000	42 1050	48 1200
L (RF)	in. mm	6.5 165	7 178	7.5 190	8 203	9 229	10 254	10.5 267	11.5 292	13 330	14 356	15 381	16 406	17 432	18 457	20 508	24 610	24 610	26 660	28 711	30 762	31 787	34 864
L1 (BW)	in. mm	6.5 165	8.5 216	9.5 241	11.13 283	12 305	15 381	15.88 403	16.5 419	18 457	19.75 502	22.5 572	24 610	26 660	28 711	32 813	36 914	36 914	38 965	40 1016	42 1067	43 1092	46 1168
L2 (RTJ)	in. mm	7.0 178	7.5 191	8 203	8.5 216	9.5 242	10.5 267	11 279	12 305	13.5 343	14.5 368	15.5 394	16.5 419	17.5 445	18.5 470	20.5 521	24.5 622	24.5 622	26.5 673	28.5 724	-	-	-
H (open)	in. mm	15.7 392	16.13 409	18.56 472	20.94 532	24.13 612	27.94 710	31.75 806	39 990	46.69 1186	55.31 1405	63.56 1615	71.31 1811	78.19 1986	87 2210	106.25 2698	119.31 3030	130.56 3317	137.25 3487	150.56 3825	183.86 4670	193.75 4920	217.5 5525
W	in. mm	7.86 200	7.86 200	7.86 200	9.86 250	9.86 250	11.81 300	11.81 300	13.75 350	17.69 450	19.69 500	18.13 460	18.13 460	18.13 460	24 610	24 610	24 610	24 610	24 610	30 760	30 760	30 760	30 760
WT (kg)	RF BW	18.5 15.5	20 17	30 26	36 29	53 46	71 66	85 77	136 116	220 202	323 294	387 350	553 506	660 575	810 720	1250 1130	1931 1765	2380 2028	2490 2280	3600 3080	4815 4840	5300 5275	7110 7050

GATE VALVE